

**Byers Gill Solar
EN010139**

6.4.12.1 Environmental Statement Appendix 12.1 Transport Statement

Planning Act 2008

APFP Regulation 5(2)(a)

Infrastructure Planning (Applications: Prescribed Forms
and Procedure) Regulations 2009

Volume 6

February 2024

Revision C01



Table of Contents

Page

1.	Introduction	1
2.	Baseline conditions	3
2.1	Existing Site Surroundings	3
2.2	Existing Highway	4
2.3	Public transport	6
3.	Development Proposals	7
3.1	Development Description	7
3.2	Construction Period	7
3.3	Trip Generation	7
3.4	Delivery Trips	7
3.5	Employee Trips	8
3.6	Total Construction Trips	9
3.7	Committed Development Trips	9
3.8	Effect of Construction Trips on Future Baseline	10
3.9	Construction Vehicle Types	10
3.10	Operational Period	10
4.	Environmental Statement and Outline Construction Traffic Management Plan	11
5.	Conclusion	12
	Appendix A Baseline Traffic Network Diagram	13
	Appendix B Construction Traffic Network Diagram	14
	Appendix C Future Baseline Traffic Network Diagram	15
	Appendix D Percentage Change Network Diagram	16
	Appendix E Proposed Access Routes and Survey Locations	17

Table of Figures

Figure 1-1 Red line boundary, Panel Areas A-F, Strategic Road Network and assessed roads (grey hash)	2
--	---

Table of Tables

Table 2-1 Access Points	3
Table 3-1 HGV trips per Panel Area	8

1. Introduction

- 1.1.1 Arup has been commissioned by RWE (The Applicant) to assess the traffic and transport impacts of a proposed solar farm development known as Byers Gill Solar (the Proposed Development). This Transport Statement accompanies an Environmental Assessment Chapter (Document Reference 6.2.12) and Outline Construction Environmental Management Plan (Document Reference 6.4.2.8).
- 1.1.2 The purpose of a Transport Statement is to provide a statement of transport conditions, through setting out the suitability of the access arrangements during the construction and operational phases of the development, outlining the expected traffic movements from the proposed development and measures that will be put in place to manage any potential transport impacts.
- 1.1.3 The Proposed Development is located east of the A1(M) between the A66, the A167, Darlington and Stockton-on-Tees. The Proposed Development consists of six sites (Panel Areas) which are currently agricultural land.
- 1.1.4 The majority of the Proposed Development's planning boundary (the Order Limits) is located within the administrative boundary of Darlington Borough Council, with a section of the cable route situated within the administrative boundary of Stockton-on-Tees Borough Council. A very small section of the Order Limits is within the administrative boundary of Durham County Council.
- 1.1.5 The proposed Development includes underground cabling between the Panel Areas and the on-site substation, as well as approximately 10km of underground cable to connect the Proposed Development to the grid connection at the existing Norton substation (located to the north-west of Stockton-on-Tees) with both on-road and off-road cabling options being considered.
- 1.1.6 **Error! Reference source not found.** depicts the red line boundary and the location of the Panel Areas, in relation to the Strategic Road Network (SRN) and assessed road network.
- 1.1.7 The Transport Statement sets out the following information:
- Baseline Conditions
 - Development Proposals
 - A summary of the Environmental Statement (ES) and Outline Construction Traffic Management Plan (CTMP)
 - Conclusion

Figure 1-1 Red line boundary, Panel Areas A-F, Strategic Road Network and assessed roads (grey hash)

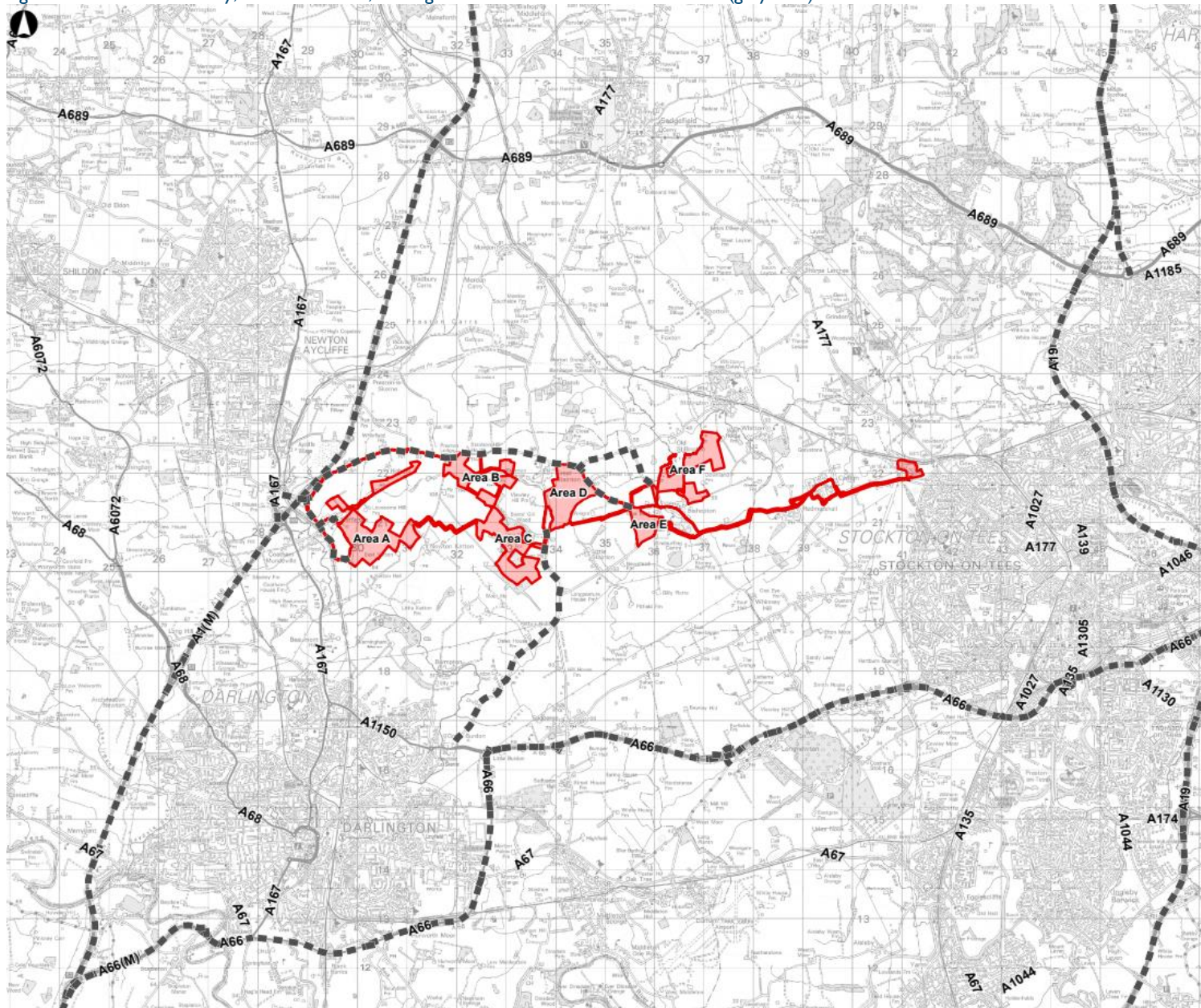

2. Baseline conditions

2.1 Existing Site Surroundings

2.1.1 At present, all proposed Panel Areas are agricultural land. Details of the location of each Panel area are as follows:

- Panel Area A: The northern section of Panel Area A is bound by the village of Brafferton to the south and by agricultural land to the north, east and west. The southern section of Panel Area A is bound by Brafferton village to the north and agricultural land to the east, south and west.
- Panel Area B: The northern boundary of Panel Area B is bound by Lodge Lane to the north, a rural road subject to the National speed limit. Agricultural land bounds Panel Area B to the east, south and west.
- Panel Area C: Panel Area C is located west of Elstob Lane / Bishopton Lane, east of Catkill Lane and bound by woodland and Byers Gill.
- Panel Area D: Panel Area D is bound by an unnamed rural road to the north, subject to the National speed limit. The proposed panel area is bound by agricultural land to the east and south and by Elstob Lane, a rural road subject the National speed limit, to the west.
- Panel Area E: Panel Area E is bound by an unnamed rural road to the north, subject to the National speed limit. Folly Bank bounds the Panel Area to the east and south. The Panel Area is further bound by agricultural land to the west.
- Panel Area F: Panel Area F is bound by Cobby Castle Lane to the west and Mill Lane to the south. The site is further bound by agricultural land to the north and east.

2.1.2 The Order Limits and Panel Areas A-F can be seen in Figure 1-1

2.1.3 All Panel Areas are proposed to use existing access points. Details of access points are as displayed in Table 2-1.

Table 2-1 Access Points

Panel Area	Access Points
Panel Area A: Brafferton	High House Lane Unnamed farm tracks off Brafferton Lane
Panel Area B: Hauxley Farm	Salters lane Unnamed farm tracks off Lodge Lane
Panel Area C: Byers Gill Wood	Bishopton Lane Elstob Lane
Panel Area D: Great Stainton	Elstob Lane Unnamed road off The Green
Panel Area E: West of Bishopton	Unnamed road off The Green
Panel Area F: North of Bishopton	Unnamed road off The Green and existing farm tracks

Panel Area	Access Points
	Mill lane from Bishopton
Norton Substation	Existing access from Letch Lane
Underground Cables	To be accessed from within Panel Areas and work undertaken along the cable route. Ongoing access would only be required should a problem occur.

2.2 Existing Highway

2.2.1 The surrounding Strategic Road Network (SRN) is comprised of the A189 to the north, the A19 to the east, the A66 to the south of the Proposed development and the A1(M) to the west.

2.2.2 The Local Road Network (LRN) surrounding the site is mainly comprised of rural single carriageways, subject to the national speed limit.

2.2.3 Main Access Routes:

- All of the sites excluding Panel Areas C and D will access the A1 (M) at junction 59 via the A167 and Lime Lane. The A167 has two traffic lanes and a pavement on both sides. Lime Lane is a C-road with no pavements and a national speed limit. Panel Areas C and D will access the A66/A1150 at Great Burdon junction via Bishopton Lane. The A1150 is a single carriageway with a left turn slip road onto the A1150 at the Great Burdon junction and a right turn island. The A1150 is subject to the National speed limit and has a shared use pavement on the northern side. The A66 is a dual carriageway subject and joins the A1150 600m east of the Great Burdon junction at a roundabout. The A66 has a shared use path on the northern side of the road for a section of the road.
- Area A has two access points, one between Aycliffe Road and High House Lane and another via an unnamed farm track off Brafferton Lane. Aycliffe Road has a national speed limit and has a pavement on the left-hand side for parts and High House Lane has a pavement on the left-hand side of the road, and has a 30mph speed limit.
- Area B has two access points, one via Salters Lane and another via an unnamed farm track off Lodge Lane. The unnamed farm track is one-way and has no pavement. Salters Lane and Lodge Lane are both C-roads with a national speed limit and no pavements.
- Area E will be accessed via an unnamed road west of The Green (Bishopton). This unnamed road is a C-road with a national speed limit and no pavements.
- Area F has two access points, one via an unnamed road north of Bishopton which will be accessed via an unnamed road east of Great Stainton, another via Mill Lane east of Bishopton. Both access roads are C-roads, with the national speed limit in place, have no pavements. Mill lane is also a single track road.

- Areas C and D will use separate access points along Elstob Lane / Bishopton Lane to meet the A66. Panel Area D will also be accessed by an unnamed road off the Green. Both are C-roads with national speed limits and have no pavements.
- The closest bus route to the sites is the 58 service that travels to Roseworth (East of Redmarshall) into the centre of Stockton-on-Tees. No formal bus routes run on along any of the access routes.
- The Study Area is served by the Tees Flex on-demand bus service. There are no formal bust stops associated with this service and pick-up/drop-off locations are selected on the associated smartphone app.
- Many of the roads within the Study Area are considered advisory cycle routes due to being low traffic roads. However, there are no official cycle lanes or National Cycle Network (NCN) routes near to the site.

2.2.4 Traffic Surveys were undertaken between 15/03/23 - 21/03/23 on the following roads and the locations of the surveys can be seen in the map in Appendix E:

- Aycliffe Lane
- The Green (Brafferton)
- Brafferton Lane
- Lime Lane
- Lodge Lane
- Elstob Lane
- Bishopton Lane North
- Bishopton Lane South
- East of Great Stainton
- West of Beach House Bank
- The Green

2.2.5 The results from the Traffic Surveys can be seen in Appendix A, the data shows that the busiest road in the Study Area (excluding the SRN) is Elstob Lane / Bishopton Lane which runs through the centre of the Proposed Development between Panel Areas A-C and Panel Areas D-F. Elstob Lane / Bishopton Lane was found to have approximately 3,000 vehicles per day in each direction. The quietest roads in the Study Area were found to be Aycliffe Lane, The Green (Brafferton) and the road west of Beach House Bank. All these roads were recorded to have on average between 100-250 vehicles in each direction per day.

2.3 Public transport

- 2.31 There is little public transport provision surrounding the Proposed Development nonetheless, a section of railway line that runs to Stockton, through Stillington, is located within proximity of the Site Area. Teesside Airport Railway Station is also located within 5km of the Proposed Development, however, there is only one Sunday service from the station per week.
- 2.3.2 The Study Area is also a zone for the TeesFlex service, a Demand Responsive Bus Service operated by Stagecoach, in partnership with the Tees Valley Combined Authority. This provides a demand responsive service for the residents of villages surrounding the Proposed Development. The frequency of TeesFlex service is dependent on demand so varies day to day. TeesFlex offers connections to Stockton, Darlington, Billingham, and Sedgefield. There are no formal bus stops for this service so pick up and drop off points are based on user demand.

3. Development Proposals

3.1 Development Description

3.1.1 The Proposed Development will comprise of six Panel Areas. The panels will be supported on framework with pile drive foundations. The Proposed Development includes underground cabling between the Panel Areas and the on-site substation, as well as approximately 10km of underground cable to connect the Proposed Development to the grid connection at the existing Norton substation (located to the north-west of Stockton-on-Tees) with both on-road and off-road options being considered.

3.1.2 A range of supporting infrastructure is required for the Proposed Development, comprising a Battery Energy Storage System (BESS); transformers and inverters for managing the electricity produced; storage containers to hold this equipment; and security measures such as fencing, CCTV and lighting. The Proposed Development includes environmental mitigation and enhancement measures to avoid or reduce adverse impacts on the surrounding environment and nearby communities.

3.2 Construction Period

3.2.1 The Environmental Assessment identifies the greatest impact of the development proposal would be during construction. The construction period of the development is expected to take between 12-18 months or 18-24 months. During this period there would be trips associated with the arrival and departure of construction staff and the delivery of construction materials. Staff trips are expected to be made by large cars (7 seat vehicles have been assumed), while deliveries of construction materials and plant will mainly be made by heavy goods vehicles (HGVs). Construction traffic is expected to use the most direct available route to the SRN and can be seen in detail in Appendix E.

3.2.2 It is expected that construction hours will be 08:00-18:00 Monday to Friday and 08:00-14:00 Saturday with no activities on Sunday or Public/Bank Holidays.

3.3 Trip Generation

3.3.1 To forecast the trip generation associated with a solar farm development we have sourced examples of similar developments from elsewhere. The construction programme assumes that three of six Panel Areas will be constructed at any given time during the construction phase of the Proposed Development. The trip generation is formed of delivery trips and employee trips and has been calculated as follows.

3.4 Delivery Trips

3.4.1 Construction delivery trips have been estimated by JBM Solar / RWE based upon other recently developed JBM Solar / RWE, UK based, solar farm, and other local sites of a similar scale to the Proposed Development. The number of trips has been estimated based on scale (kilowatt outputs) from previous projects resulting in an estimate of 36

trips (72 two way trips) across the Proposed Development. These trips have been distributed across each Panel Area proportional to its approximate size to understand how many trips each Panel Area could generate.

- 3.4.2 Based upon the trips assigned to each Panel Area, the construction traffic has been assumed to route to the Strategic Network; A1(M) and A66 using the most appropriate route according to Google Maps whilst considering weight limit restrictions and avoiding residential villages. Appendix E shows the proposed routing for each Panel Area.
- 3.4.3 Table 3-1 presents the assumed vehicle delivery trips during construction to the Proposed Development, per Panel Area, and the Strategic Road construction traffic is assumed to use.

Table 3-1 HGV trips per Panel Area

Panel Area	Approx Hectare Size (ha)	Construction Trips	Strategic Road
A	114.34	8	A1(M)
B	52.51	4	A1(M)
C	110.72	8	A66
D	87.90	6	A66
E	26.64	2	A1(M)
F	104.89	8	A1(M)
Average		6	
Total		36	

- 3.4.4 A network diagram, showing how the trips have been distributed on the network can be found in Appendix B.
- 3.4.5 The expected vehicle trips are based on worst-case scenario estimates at this stage and will be dependent upon the final construction programme.

3.5 Employee Trips

- 3.5.1 It is expected that three sites will be constructed at any given time during the construction phase of the Proposed Development, and that each site could require up to 100 employees (300 on site at any one time). Based on similar sites constructed elsewhere, employees are expected to travel to the site in groups, with other sites suggesting large cars or minibuses are generally used to transport staff. A vehicle occupancy of 7 staff per vehicle has been assumed. This is forecast to result in approximately 15 car/LGV trips to each site (30 two-way movements).

- 3.5.2 Similar to the large occupancy delivery vehicles, the employee trips are assumed to route to the Strategic Network; A1(M) and A66 using the most appropriate route according to Google Maps whilst considering weight limit restrictions and avoiding residential villages. Appendix E shows the proposed routing for each Panel Area.
- 3.5.3 It is expected that staff trips will arrive before the network AM peak and depart after the network PM peak due to the proposed working hours.
- 3.5.4 Car parking for construction workers will be provided within the site compound.

3.6 Total Construction Trips

- 3.6.1 An assumption of the assessment is that a maximum of three Panel Areas will be constructed at any given time. As it is not known which three Panel Areas might be constructed at once, the assessment assumes trips for all Panel Areas with each road capped to the average trips of three Panel Areas, in order to assess the impact.
- 3.6.2 The average trips of three Panel Areas for construction delivery trips produces a cap of 18 HGVs (36 two way movements) per day. It is acknowledged that if the three largest Panel Areas were constructed at once, each expected to generate eight HGV trips, a maximum of 24 HGV trips (48 two way movements) could travel to the study area each day. Across three sites, the employee trips could generate 45 car trips (90 two-way movements). Therefore, the total forecast HGV and staff trips, to three Panel Areas, would be 63 vehicles (126 two way movements), on average, during the construction phase. In the very worst case where the three largest Panel Areas are built simultaneously 69 vehicles (138 two way movements) could be expected within the network.
- 3.6.3 The Network Diagram in Appendix B shows the maximum impact the construction trips will have on any road within the network.

3.7 Committed Development Trips

- 3.7.1 The potential overlap with traffic from other developments within the vicinity has been considered. Those committed developments that would use routes within the Study Area have been identified and any additional vehicle trips on those routes have been included in the future baseline scenario. Developments considered include;
- Gately Moor Solar Farm (22/00727/FUL)
 - Whinfield Solar Farm (21/00958/FUL)
 - Forrest Park (DM/19/00283/OUT)
 - Plot 3B Merchant Park Millenium Way Aycliffe Business Park (DM/23/02905/FPA)
 - Concrete plant Aycliffe Quarry (DM/23/03701/WAS)
- 3.7.2 Other developments have been considered and excluded from the future baseline for various reasons, see ES Chapter 13 Cumulative Effects for further information.

- 3.7.3 These committed trips have been included alongside the traffic survey to generate a future baseline scenario which can be seen in Appendix C.

3.8 Effect of Construction Trips on Future Baseline

- 3.8.1 The percentage change of the Proposed Developments total construction trips compared to the future baseline has been calculated to assess the impact the Proposed Development will have on the network. The network diagram of the percentage change impact of the Proposed Development construction trips on the future baseline can be seen in Appendix D.
- 3.8.2 During the construction phase, the majority of roads within the study area see an increase of less than 10%.
- 3.8.3 There are however some routes where construction traffic would temporarily increase daily traffic flows by more than 10% as shown in Appendix D. Lime Lane is forecast to see an increase of up to 12% in daily traffic flows and Aycliffe Lane an increase of up to 20%. However, these roads are subject to low existing traffic flows, as shown in the baseline data in Appendix A, and as such a small increase in trips will show a high percentage change in traffic flow.

3.9 Construction Vehicle Types

- 3.9.1 The vehicles travelling to the Proposed Development will generally be standard construction and use HGVs with a maximum length of 16.5 (articulated).
- 3.9.2 There is however expected to be the requirement for two abnormal loads to travel to the site, to deliver sub-station components to Panel Area C. They are considered abnormal due to the weight of the load, rather than dimensions of the load. The weight of these movements would be over the 44 tonnes which is the threshold for a normal load. The preference is for these to reach the sub-station site from the A66. The proposed routeing, which follows the route to Panel Area C, is shown in Appendix E. However, the use of this route to transfer the abnormal load will be subject to agreement with the highway authorities at the time the application to transfer the abnormal load is made, and therefore could change at the request of the highway authorities.

3.10 Operational Period

- 3.10.1 Once the solar farm is fully operational, there will be no staff based on site. It will not generate any significant traffic movements, with security and maintenance staff the only occasional visitors. These trips would typically be made by small vans and 4 x 4 vehicles.
- 3.10.2 No moving parts means very little maintenance is required. Based on information from other solar farm sites maintenance that does take place will be carried out by an engineer with visits expected to be one trip (2 two-way movements) per month to each Panel Area.

4. Environmental Statement and Outline Construction Traffic Management Plan

- 4.1.1 A Traffic and Transport Assessment has been produced as part of the Environmental Statement (ES) (Document Reference 6.2.12), and an Outline Construction Traffic Management Plan (Document Reference 6.4.2.8) has also been developed in support of the Proposed Development.
- 4.1.2 The purpose of the ES is to enable local planning authorities or Secretary of State to come to a reasoned conclusion on the significant effects of the proposed development on the environment. The Traffic and Transport chapter's specific purpose is to assess the likely significant effects of the Proposed Development in terms of transport and access. A summary of findings from the ES are;
- Construction – The Proposed Development is generally expected to have negligible impacts on the traffic and transport network, although the assessment concludes there could be a minor adverse effect on driver delay if cable routes are constructed on-road as drivers would experience some delay due to the possibility of temporary lane closures and diversions during the construction period.
 - Operation – All effects on traffic and transport during the operational phase are considered to be negligible; and
 - Decommissioning – Similarly, at this stage all effects of decommissioning are forecast to be negligible.
- 4.1.3 The Outline Construction Traffic Management Plan identifies measures to minimise the effect of construction traffic on the surrounding highway network. The Outline Construction Traffic Management Plan provides details on:
- Defined routes for HGVs to and from each Panel Area that are identified as suitable for the size of vehicles, and which avoid populated areas where possible;
 - Controls under health and safety legislation (wheel washing facilities, the cleaning of access roads if required etc.); and
 - How the impact of construction traffic including noise, vehicle emissions, dust, mud and debris on roads will be mitigated through strict adherence to the proposed construction routes and permitted hours of working, which in turn are expected be controlled by planning conditions.
- 4.1.4 The Outline Construction Traffic Management Plan will be updated by the Principal Contractor upon appointment, prior to the commencement of construction, into a detailed Construction Traffic Management Plan under requirement 6 of the DCO.

5. Conclusion

5.1.1 This Transport Statement outlines the development proposals, the baseline transport conditions and reviews the potential effect of the development on the local transport network. Key findings include:

- The Panel Areas are located in a rural area, with access locations being the existing access points to areas of agricultural land;
- Access to all Panel Areas for the construction and operational phase of the Proposed Development is via existing agricultural access points;
- Traffic surveys collected in 2023 show that routes within the study area are generally lightly trafficked;
- There is limited access to the Proposed Development by public transport. Similarly, there are no National Cycle routes, albeit many of the roads within the area are identified on the Council cycle maps as advisory routes;
- The trip generation of the Proposed Development has been forecast based on solar farm developments that have been constructed elsewhere. On average, there is expected to be approximately 15 staff trips and 6 HGV movements to each Panel Area per day during the construction period;
- Once the solar farm is operational, it will not generate any significant traffic movements, with security and maintenance staff the only likely regular visitors; and
- A supporting Environmental Statement has assessed the traffic and transport impacts of the Proposed Development. An Outline Construction Traffic Management Plan has been developed to minimise impacts during construction. The residual effects are expected to be negligible, with the exception of the effect on driver delay which could be a minor adverse effect if the cable routes are on-road.

5.1.2 Therefore, based on the information gathered and reviewed in this Transport Statement, there are considered to be no highway related reasons to not permit the Proposed Development.

Appendix A Baseline Traffic Network Diagram

Baseline Traffic

	% HGVs
	Vehicle Count

Notes
 Survey undertaken over 24 hours per day between 15/03/23-21/03/23.
 Diagram represents the 7 day average.

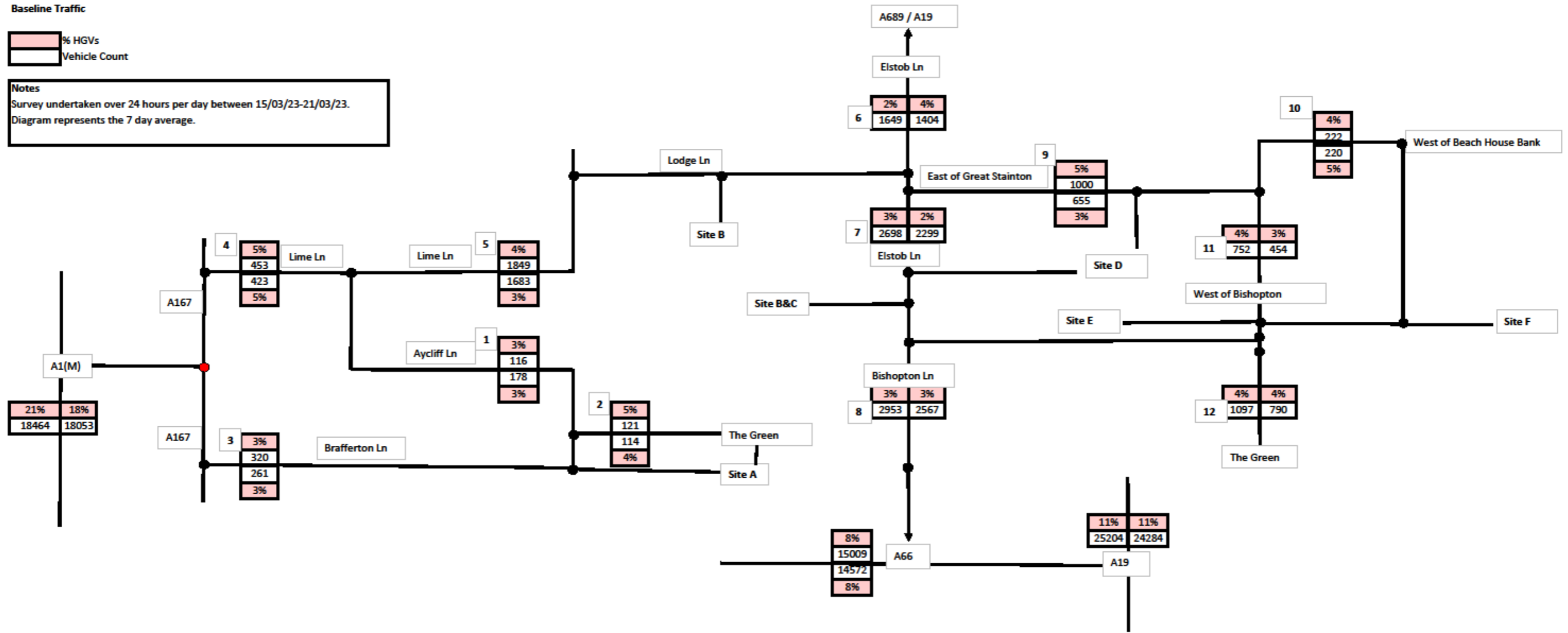

Appendix B Construction Traffic Network Diagram

Construction Traffic

	% HGVs
	Vehicle Count

Notes
 Construction traffic is routed based on quickest available route to the SRN (excluding Site E and F).
 Diagram shows a maximum of 3 sites worth of traffic on each road to represent the worst case scenario.
 Diagram represents the daily average.

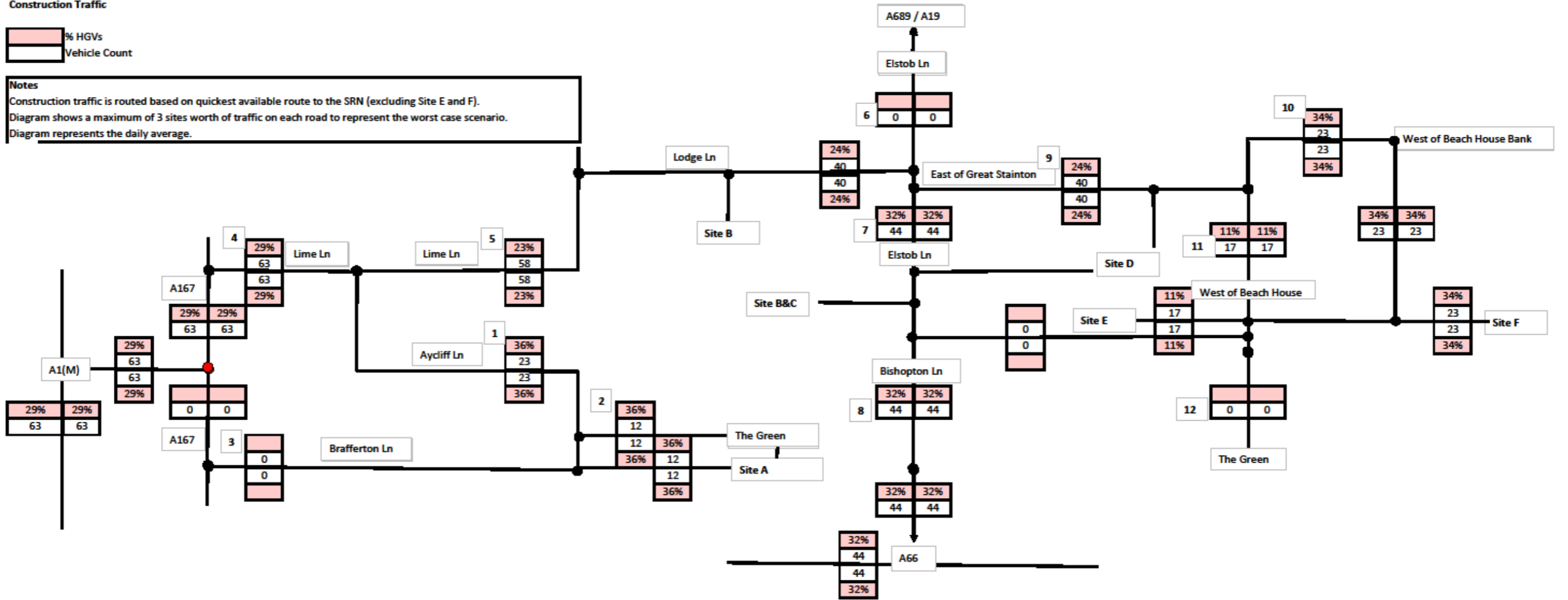

Appendix C Future Baseline Traffic Network Diagram

Future Traffic

Vehicle Count

Notes
 Survey undertaken over 24 hours per day between 15/03/23-21/03/23.
 Diagram represents the 7 day average.
 Future traffic during construction including baseline and committed trips

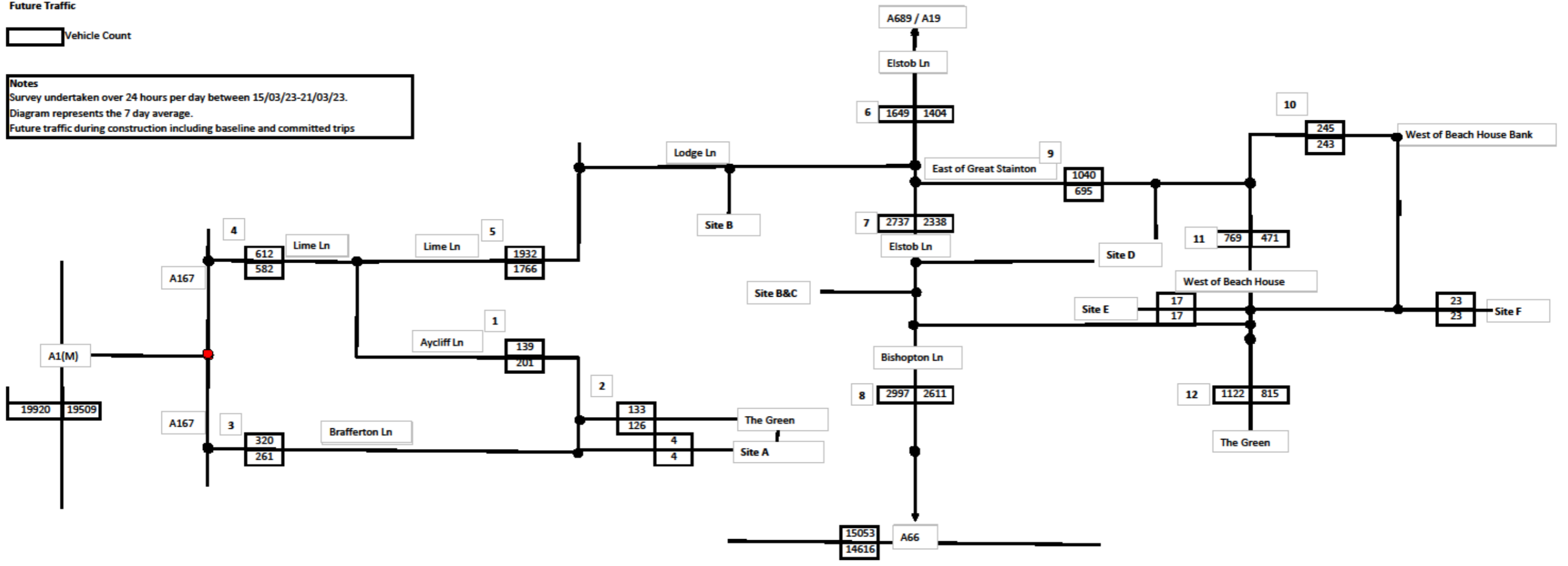

Appendix D Percentage Change Network Diagram

Construction Traffic Percentage Change

Vehicle Count

Notes
Percentage change in vehicle numbers from the future baseline

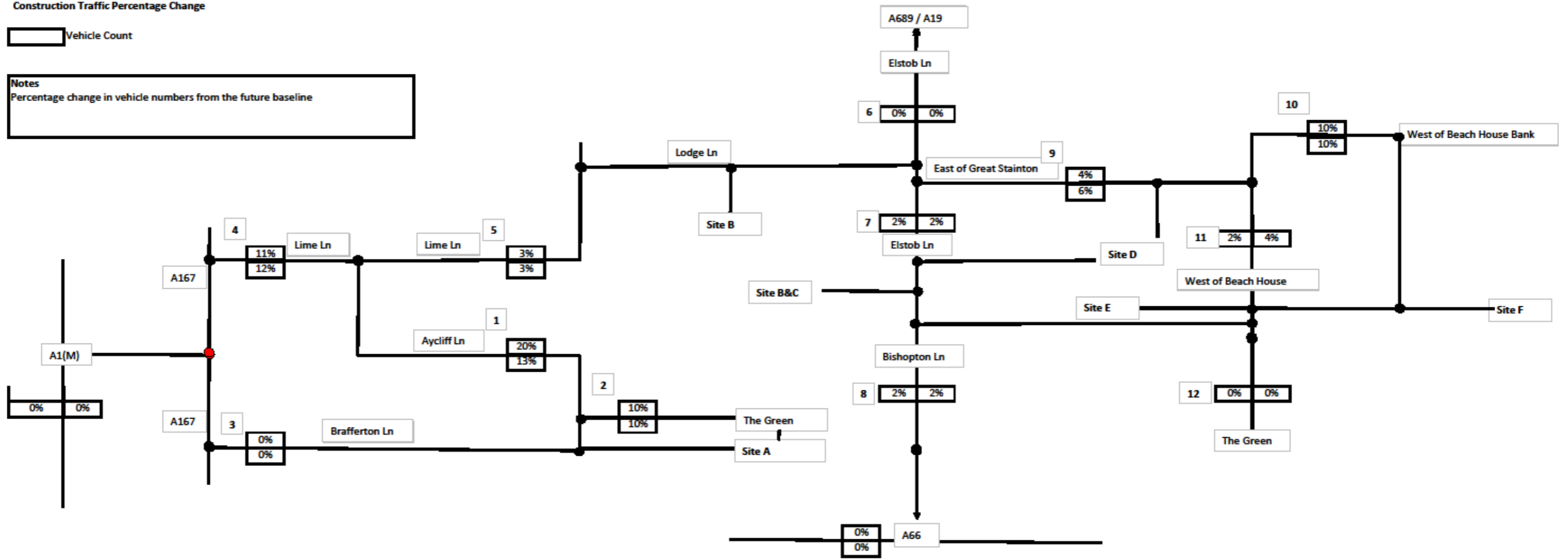

Appendix E Proposed Access Routes and Survey Locations

